

NE58H9970WS

5.8 CU. FT. FLEX DUO™ SLIDE-IN INDUCTION RANGE

CHEF COLLECTION

Our premium Chef Collection line is designed by Master Chefs with the sophisticated cook in mind. Every appliance in the collection has been tested and approved by Michelin Star chefs to build the best kitchen possible.

FEATURES

- Premium Slide-in Design
- Flex Duo™ Technology – traditional single cavity range and double oven in one; unique design easily switches from single cavity to two smaller cavities
- Chef Bake – Precise Temperature Control for Optimal Results
- Four Induction Elements – 11", 6", two 7"
- Glass Touch Controls with Guiding Light System
- Dual Convection for Even Cooking
- Gliding Rack for Simplest Access to Food in the Oven
- Temperature Probe Ensures Best Cooking Results
- Large Oven Capacity – 5.8 cu. ft.
- Warming Drawer: High, Medium, Low
- SteamQuick™ (20 min. oven cleaning) and Self Clean

CONVENIENCE

- Hot Surface Indicator Lights
- Auto Oven Light
- Proofing
- Sabbath Mode
- Kitchen Timer
- Delay Start
- Auto Shut-Off Option
- Child Safety Lock
- 5 Healthy Cook Presets



Ranked **"Highest in Customer Satisfaction with Ranges, Cooktops and Ovens."***

– J.D. Power



Full Induction Cooktop with Virtual Flame Technology



Guiding Light Controls

Available Colour



Stainless Steel

SIGNATURE FEATURES

FULL INDUCTION COOKTOP WITH VIRTUAL FLAME TECHNOLOGY

- Induction cooking focuses the most heat directly to the pot so that you can boil and cook faster, plus simmer with more control. Induction cooking uses heat more efficiently as compared to electric and gas.*
- LED lights shine onto pots and pans to provide the visual of gas cooking with the precision of induction.

* Based on laboratory testing when compared with Samsung Electric and Samsung Gas cooktop ranges

FLEX DUO OVEN

- The spacious 5.8 cu. ft. oven splits into two ovens with the Smart Divider™ to cook at two different temperatures at the same time.
- No noticeable transfer of aroma.

CHEF BAKE

- Chef Bake regulates the heat level and delivers consistent cooking temperature, minimizing fluctuations.

PREMIUM DESIGN WITH GUIDING LIGHT CONTROLS

- Intuitive controls offer simple, step-by-step instructions for choosing cooking options.
- Only illuminates cooking options that are able to be selected and goes from left to right, eliminating back and forth.
- Control temperature and time settings, select cooking functions and program your favourite recipes.

SAMSUNG

NE58H9970WS

5.8 CU. FT. FLEX DUO™ SLIDE-IN INDUCTION RANGE

INSTALLING YOUR RANGE

*30" minimum clearance between the top of the cooking surface and the bottom of an unprotected wood or metal cabinet; or 24" minimum when the bottom of the wood or metal cabinet is protected by not less than 1/4" flame-retardant millboard covered with not less than no. 28 MSG sheet steel, 0.015" stainless steel, 0.024" aluminum or 0.020" copper.

**18" minimum between the countertop and the adjacent cabinet bottom.

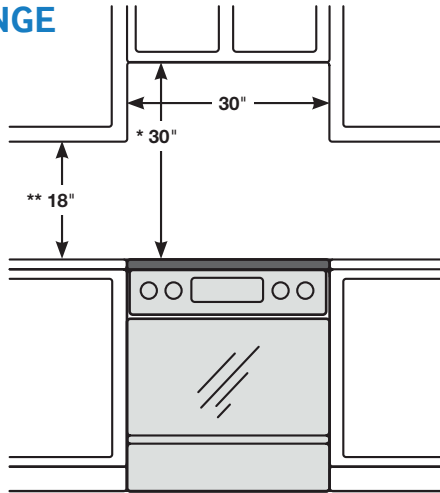

IMPORTANT: To eliminate the risk of burns or fire caused by reaching over heated surface units, cabinet storage space located above the surface units should be avoided. If cabinet storage is to be provided, the risk can be reduced by installing a range hood that projects horizontally a minimum of 5" beyond the bottom of the cabinets.

DIMENSIONS

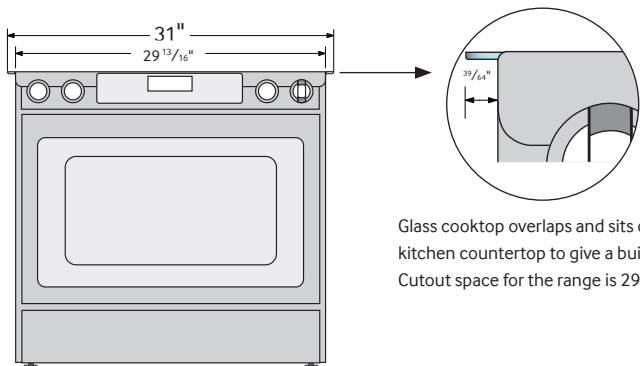

Glass cooktop overlaps and sits on top of your kitchen countertop to give a built-in look. Cutout space for the range is 29 13/16".

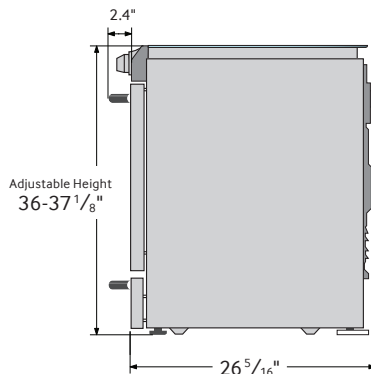

Induction Cooktop

- Left Front: 7", 1.8 kW (Boost 2.3 kW)
- Right Front: 11", 2.3 kW (Boost 3.3 kW)
- Right Rear: 6", 1.2 kW (Boost 2.0 kW)
- Left Rear: 7", 1.8 kW (Boost 2.3 kW)

Dual Oven (with Divider)

- Hidden Bake Element: 3000 W
- Bake: 150°F-550°F (66°C-288°C)
- Convection Bake: 175°F-550°F (79°C-288°C)
- Convection Roast: 175°F-550°F (79°C-288°C)
- Variable Broil (Low - High)
- Convection Element/Heater: 1250 W
- Proofing
- Sabbath Mode

Warming Drawer

- Capacity – 0.7 cu. ft.
- Heating Performance: 600 W (4 pass)
- Temperature Settings: High, Medium, Low

Warranty

One (1) Year All Parts and Labour
Five (5) Years Electric Cooktop

Product Dimensions & Weight (WxHxD)

Outside Dimensions:
29 13/16" x 36-37 1/8" (Adjustable) x 26 5/16"

Weight: 233.7 lbs.

Shipping Dimensions & Weight (WxHxD)

Dimensions:
33 1/32" x 41 3/4" x 30 9/32"

Weight: 257.9 lbs.

Colour	Model #	UPC Code
Stainless Steel	NE58H9970WS	887276033020

*Samsung received the highest numerical score for ranges, cooktops and ovens in the proprietary J.D. Power 2014 Kitchen Appliance StudySM Study based on 15,380 total responses measuring 17 ranges, cooktops and oven brands and measures opinions of consumers about their new appliance purchased in the past 24 months. Proprietary study results are based on experiences and perceptions of consumers surveyed in January-March 2014. Your experiences may vary. Visit jdpower.com.

Actual colour may vary. Design, specifications, and colour availability are subject to change without notice. Non-metric weights and measurements are approximate. Clearance requirements are the recommended minimum only. Check the regulations and codes in your area for any additional requirements.

© 2015 Samsung Electronics Canada Inc. All rights reserved. Samsung is a registered trademark of Samsung Electronics Co., Ltd., used with permission.

SAMSUNG